



内转子直流无刷电动机 89系列 INTERNAL ROTOR DC BRUSHLESS MOTOR 89 SERIES

额定电压: DC310V	Nominal Voltage: DC310V
转速信号: 12脉冲/转	Tach Output: 12Pulse/R
控制方式: 0~6.5VDC/PWM	Speed Control: 0~6.5VDC/PWM
绝缘等级: B级	Insulation Class: B
认证: CCC CE	Approvals: CCC CE

产品主要技术参数 Product main technical parameters

型号 Type	额定电压 Nominal Voltage [VDC]	转速 Speed [r/min]	输出功率 Power Output [W]	使用温度 Perm. amb. temp. [°C]
M3P-DC089-3XX	310	300~3000	0~30	-25~+60
M3P-DC089-6XX	310	300~3000	0~50	-25~+60

电机安装及结构尺寸说明 Motor installation and structure dimensions explanation

型号 Type	A 轴径 Axle Diameter	B1 电机厚度一 Motor Thickness 1	B2 电机厚度二 Motor Thickness 2	C 安装面尺寸 Installation Size
M3P-DC089-3XX	φ8	59.4	44.8	37.3
M3P-DC089-6XX	φ8	71.4	56.8	37.3

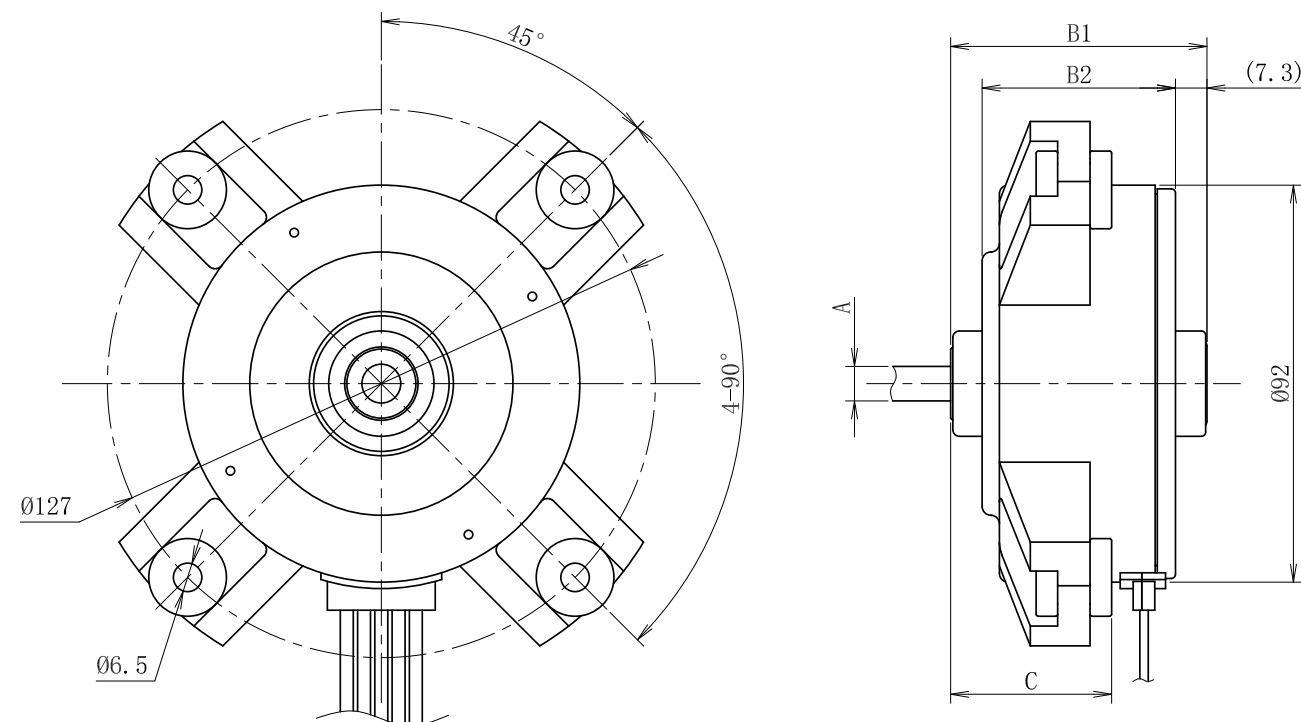

内转子直流无刷电机接线图 (DC310V) Electrical Connections For DC Motor With Inner Rotor

引线1 Line1

VS	GND	Vcc	0~6.5V PWM	Tach
红 red	黑 black	白 white	黄 yellow	蓝 blue

引线 Line	连接器 Connection	颜色 Colour	功能 function
1	VS	红色 red	DC310V
	GND	黑色 black	GND
	Vcc	白色 white	DC15V IC工作电压 IC Supply Input
	Vsp	黄色 yellow	0~6.5VDC/PWM 转速控制输入 Speed Control Input
	TACH	蓝色 blue	转速信号输出 Tach Output 12 Pulse/R

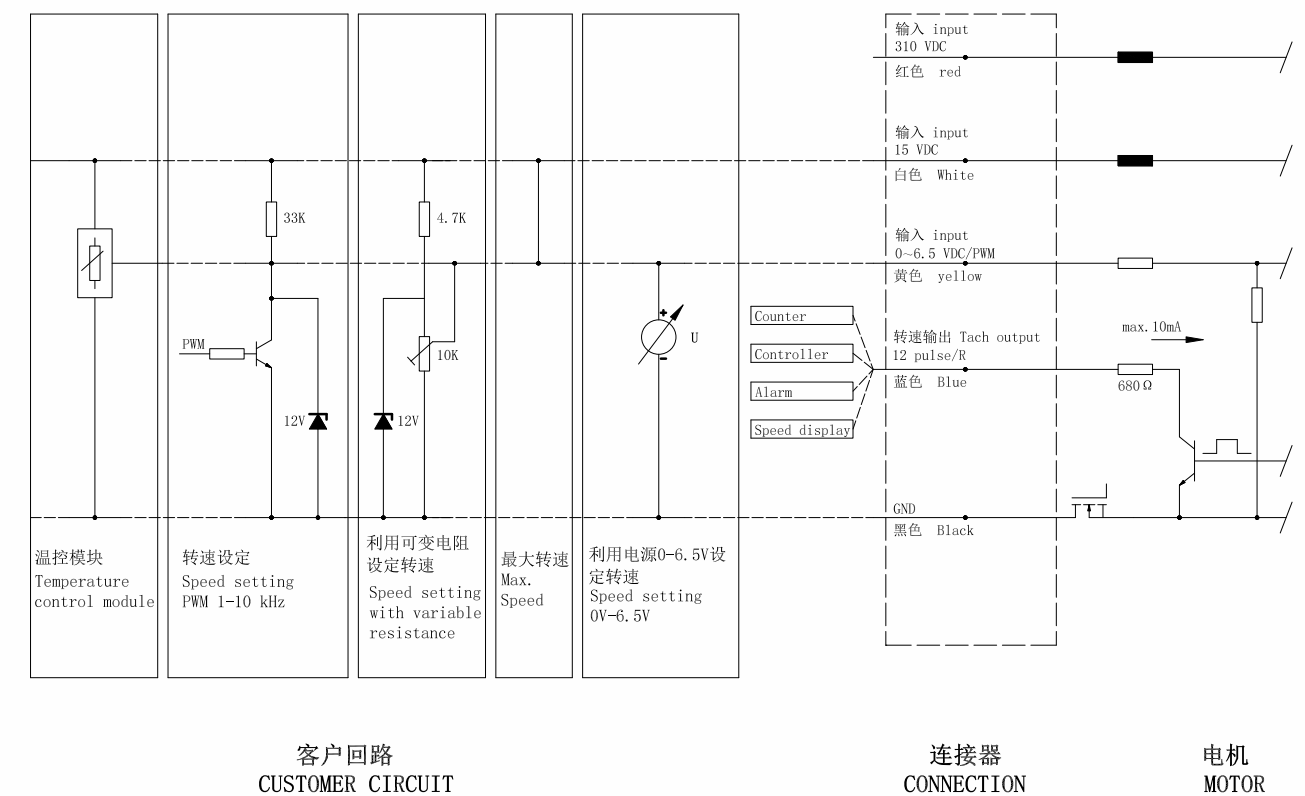



内转子直流无刷电动机 89系列
INTERNAL ROTOR DC BRUSHLESS
MOTOR 89 SERIES

额定电压: DC310V	Nominal Voltage: DC310V
转速信号: 12脉冲/转	Tach Output: 12Pulse/R
控制方式: 0~6.5VDC/PWM	Speed Control: 0~6.5VDC/PWM
绝缘等级: B级	Insulation Class: B
认证: CCC CE	Approvals: CCC CE

产品主要技术参数 Product main technical parameters

型号 Type	额定电压 Nominal Voltage [VDC]	转速 Speed [r/min]	输出功率 Power Output [W]	使用温度 Perm. amb. temp. [°C]
M3P-DC089-3XX	310	300~3000	0~30	-25~+60
M3P-DC089-6XX	310	300~3000	0~50	-25~+60

电机安装及结构尺寸说明 Motor installation and structure dimensions explanation

型号 Type	A 轴径 Axle Diameter	B1 电机厚度一 Motor Thickness 1	B2 电机厚度二 Motor Thickness 2	-----
M3P-DC089-3XX	φ8	59.4	44.8	-----
M3P-DC089-6XX	φ8	71.4	56.8	-----

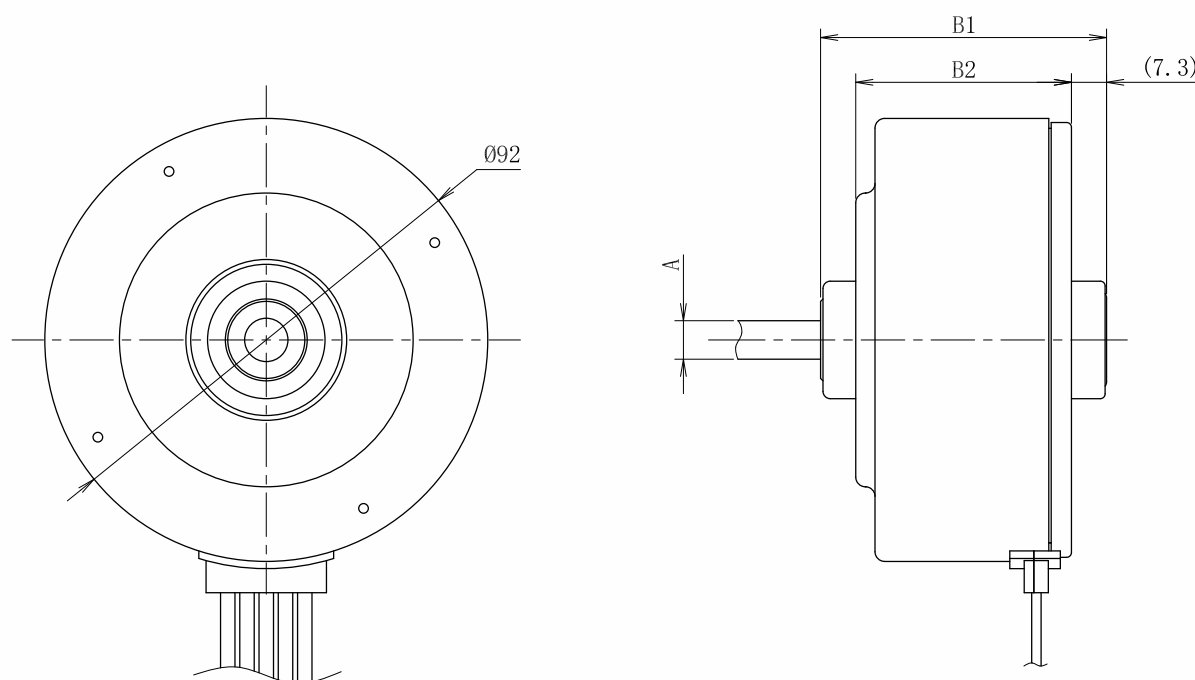

内转子直流无刷电机接线图 (DC310V)
Electrical Connections For DC Motor With Inner Rotor

引线1 Line1

VS	GND	Vcc	0~6.5V PWM	Tach
红 red	黑 black	白 white	黄 yellow	蓝 blue

引线 Line	连接器 Connection	颜色 Colour	功能 function
1	VS	红色 red	DC310V
	GND	黑色 black	GND
	Vcc	白色 white	DC15V IC工作电压 IC Supply Input
	Vsp	黄色 yellow	0~6.5VDC/PWM 转速控制输入 Speed Control Input
	TACH	蓝色 blue	转速信号输出 Tach Output 12 Pulse/R

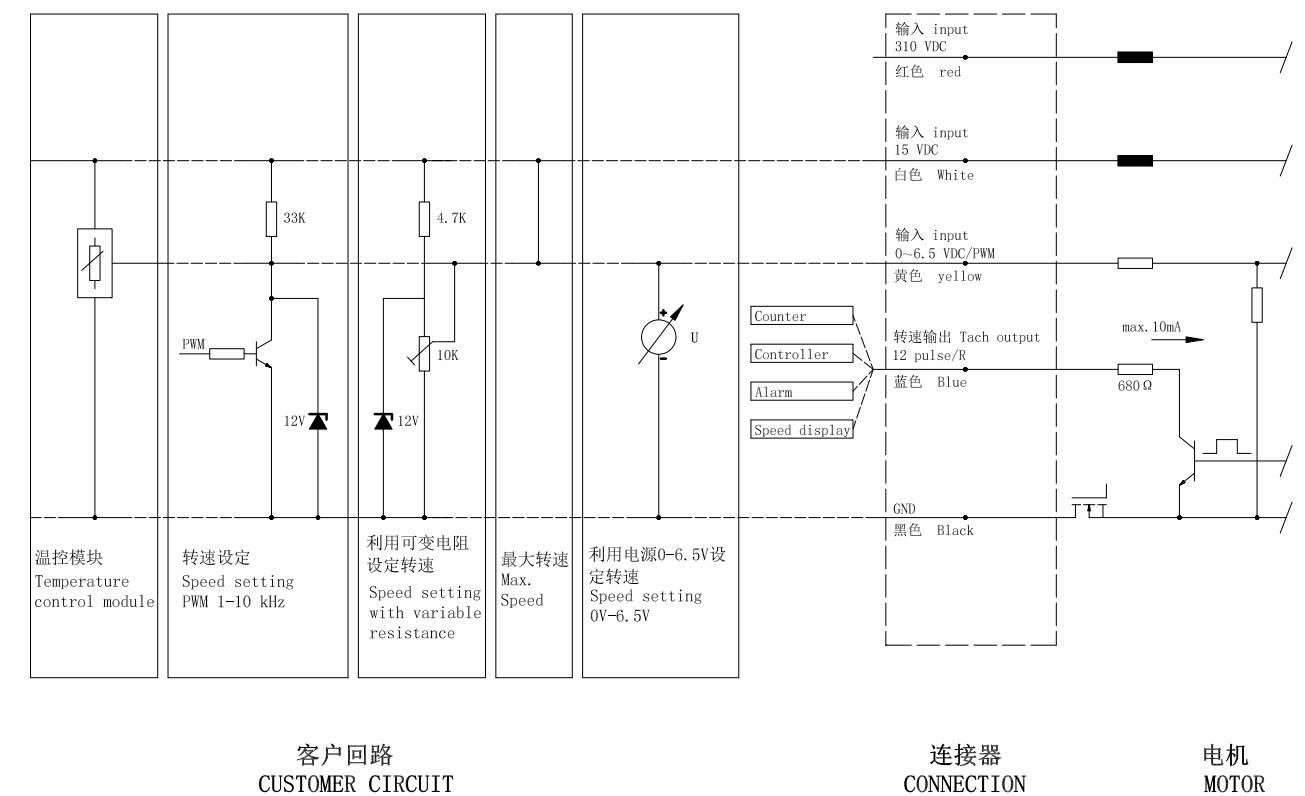



内转子直流无刷电动机 95系列 INTERNAL ROTOR DC BRUSHLESS MOTOR 95 SERIES

额定电压: DC310V	Nominal Voltage: DC310V
转速信号: 12脉冲/转	Tach Output: 12Pulse/R
控制方式: 0~6.5VDC/PWM	Speed Control: 0~6.5VDC/PWM
绝缘等级: B级	Insulation Class: B
认证: CCC CE	Approvals: CCC CE

产品主要技术参数 Product main technical parameters

型号 Type	额定电压 Nominal Voltage [VDC]	转速 Speed [r/min]	输出功率 Power Output [W]	使用温度 Perm. amb. temp. [°C]
M3P-DC095-3XX	310	300~3000	0~70	-25~+60
M3P-DC095-6XX	310	300~3000	0~90	-25~+60

电机安装及结构尺寸说明 Motor installation and structure dimensions explanation

型号 Type	A 轴径 Axle Diameter	B1 电机厚度一 Motor Thickness 1	B2 电机厚度二 Motor Thickness 2	C 安装面尺寸 Installation Size
M3P-DC095-3XX	φ8/φ12	81.5	70	55.2
M3P-DC095-6XX	φ12	93.5	82	67.2

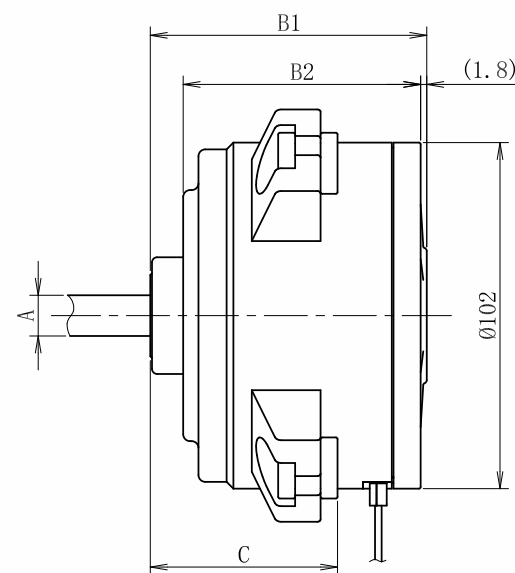
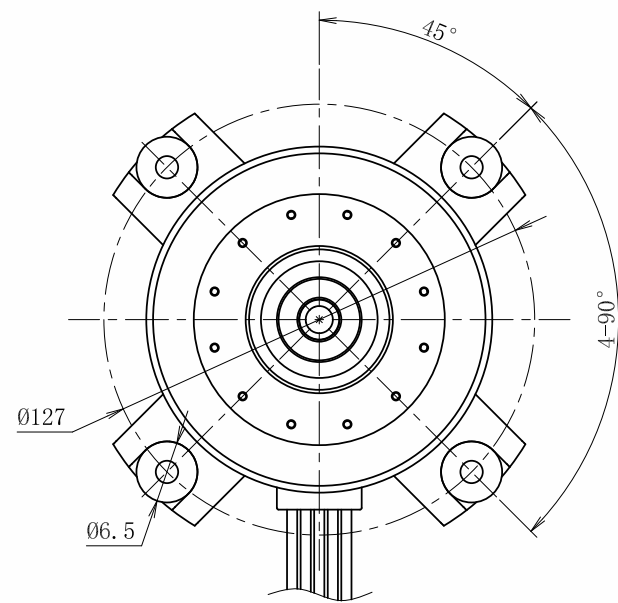

内转子直流无刷电机接线图 (DC310V) Electrical Connections For DC Motor With Inner Rotor

引线1 Line1

VS	GND	Vcc	0-6.5V PWM	Tach
红 red	黑 black	白 white	黄 yellow	蓝 blue

引线 Line	连接器 Connection	颜色 Colour	功能 function
1	VS	红色 red	DC310V
	GND	黑色 black	GND
	Vcc	白色 white	DC15V IC工作电压 IC Supply Input
	Vsp	黄色 yellow	0-6.5VDC/PWM 转速控制输入 Speed Control Input
	TACH	蓝色 blue	转速信号输出 Tach Output 12 Pulse/R

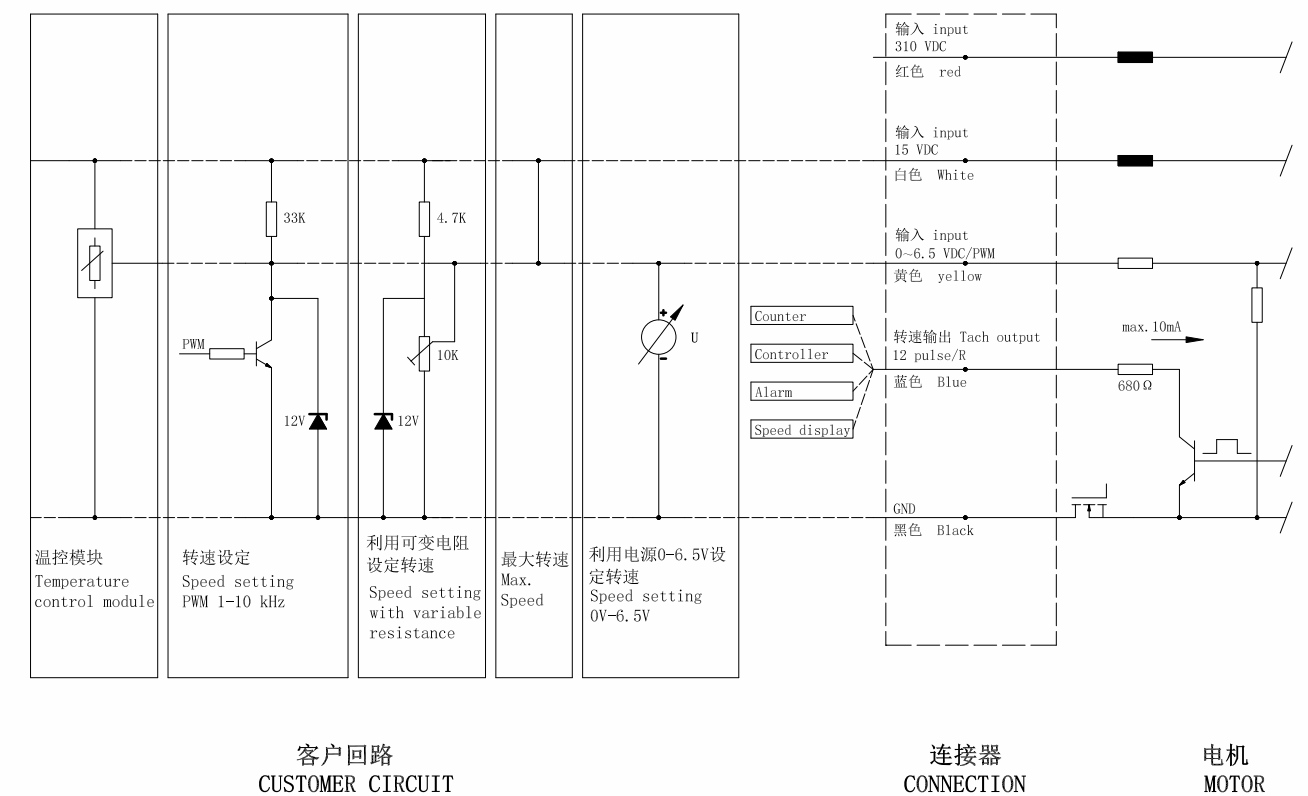



内转子直流无刷电动机 108系列 INTERNAL ROTOR DC BRUSHLESS MOTOR 108 SERIES

额定电压: DC310V	Nominal Voltage: DC310V
转速信号: 12脉冲/转	Tach Output: 12Pulse/R
控制方式: 0~6.5VDC/PWM	Speed Control: 0~6.5VDC/PWM
绝缘等级: B级	Insulation Class: B
认证: CCC CE	Approvals: CCC CE

产品主要技术参数 Product main technical parameters

型号 Type	额定电压 Nominal Voltage [VDC]	转速 Speed [r/min]	输出功率 Power Output [W]	使用温度 Perm. amb. temp. [°C]
M3P-DC108-3XX	310	300~3000	0~150	-25~+60
M3P-DC108-6XX	310	300~3000	0~250	-25~+60

电机安装及结构尺寸说明 Motor installation and structure dimensions explanation

型号 Type	A 轴径 Axle Diameter	B1 电机厚度一 Motor Thickness 1	B2 电机厚度二 Motor Thickness 2	C 安装面尺寸 Installation Size
M3P-DC108-3XX	φ12/φ15	90.4	77	62.3
M3P-DC108-6XX	φ15	105.4	92	77.3

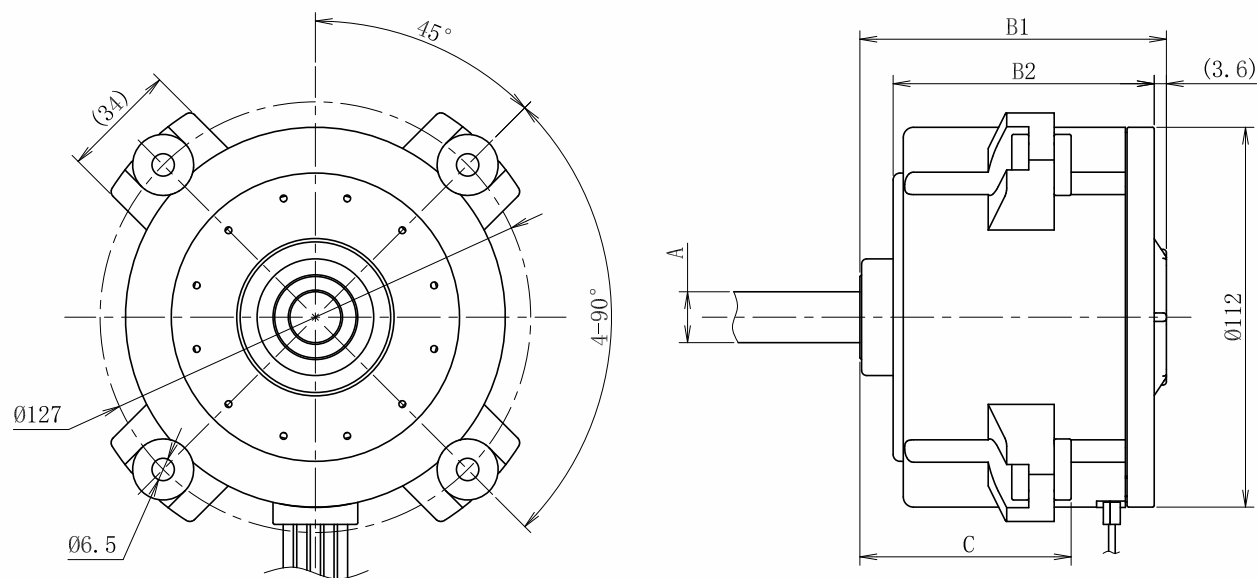

内转子直流无刷电机接线图 (DC310V) Electrical Connections For DC Motor With Inner Rotor

引线1 Line1

VS	GND	Vcc	0-6.5V PWM	Tach
红 red	黑 black	白 white	黄 yellow	蓝 blue

引线 Line	连接器 Connection	颜色 Colour	功能 function
1	VS	红色 red	DC310V
	GND	黑色 black	GND
	Vcc	白色 white	DC15V IC工作电压 IC Supply Input
	Vsp	黄色 yellow	0-6.5VDC/PWM 转速控制输入 Speed Control Input
	TACH	蓝色 blue	转速信号输出 Tach Output 12 Pulse/R

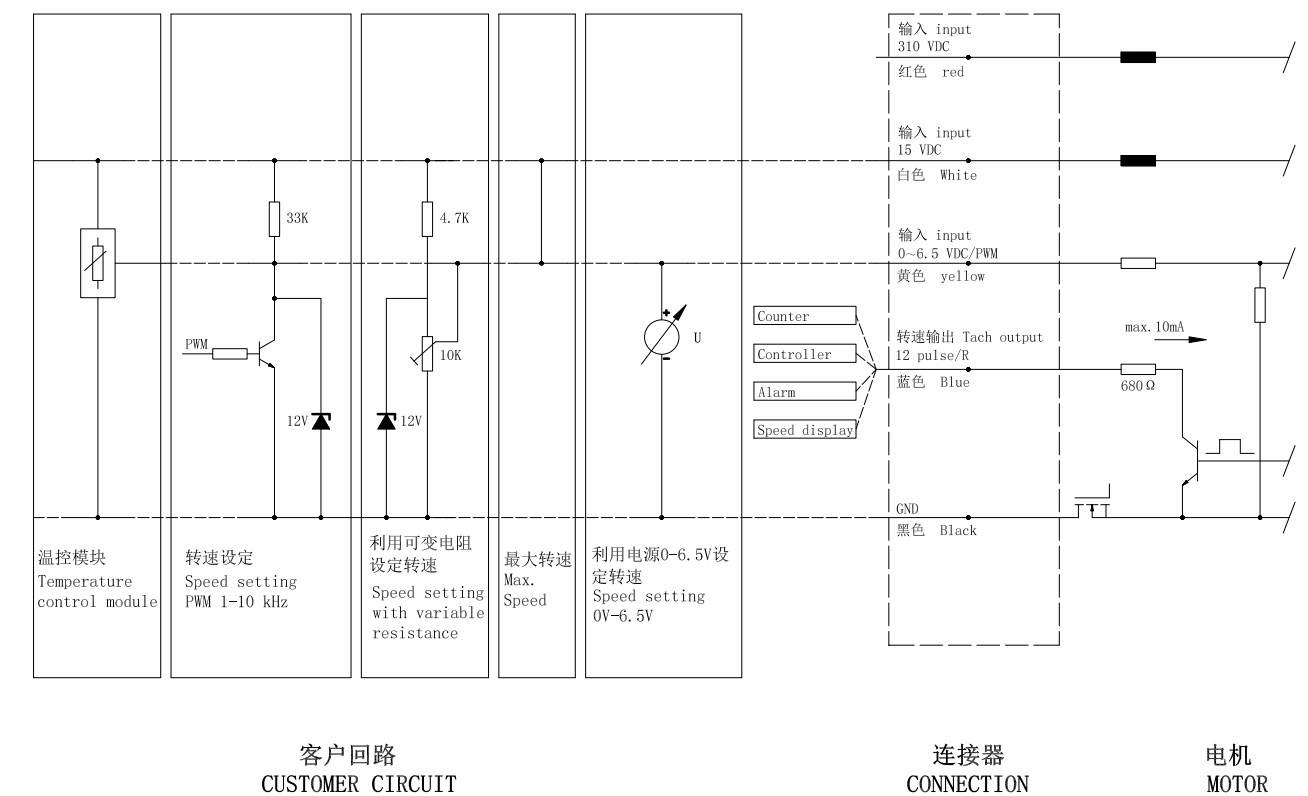



内转子直流无刷电动机 76系列 INTERNAL ROTOR DC BRUSHLESS MOTOR 76 SERIES

额定电压: DC24V Nominal Voltage: DC24V
 转速信号: 4脉冲/转 Tach Output: 4Pulse/R
 控制方式: 0~5VDC/PWM Speed Control: 0~5VDC/PWM
 绝缘等级: E级 Insulation Class: E
 认 证: ----- Approvals: -----

产品主要技术参数 Product main technical parameters				
型号 Type	额定电压 Nominal Voltage [VDC]	转速 Speed [r/min]	输出功率 Power Output [W]	使用温度 Perm. amb. temp. [°C]
M3P-DC076-XXX	24	300~8000	0~30	-25~+60
M3P-DC076-XXX	24	300~8000	0~60	-25~+60

电机安装及结构尺寸说明 Motor installation and structure dimensions explanation				
型号 Type	A 轴径 Axle Diameter	B1 电机厚度一 Motor Thickness 1	B2 电机厚度二 Motor Thickness 2	-----
M3P-DC076-XXX	φ8	42.5	32	-----
M3P-DC076-XXX	φ8	46.2	36	-----

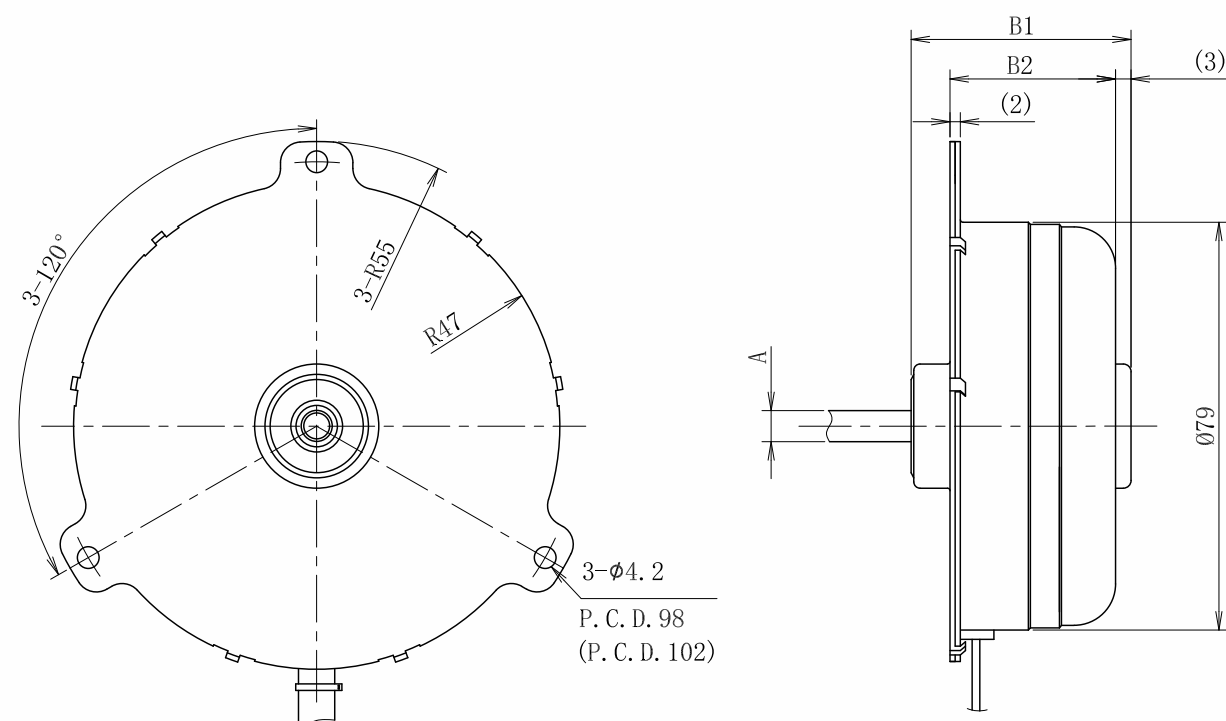

内转子直流无刷电机接线图 (DC24V) Electrical Connections For DC Motor With Inner Rotor

引线1 Line1			
引线 Line	连接器 Connection	颜色 Colour	功能 function
	VS	红色 red	DC24V
	GND	黑色 black	GND
	Vcc	白色 white	DC12V IC工作电压 IC Supply Input
	Vsp	黄色 yellow	0-5VDC/PWM 转速控制输入 Speed Control Input
	TACH	蓝色 blue	转速信号输出 Tach Output 4 Pulse/R

